



Cambridge International Examinations
Cambridge International General Certificate of Secondary Education

CANDIDATE
NAME

CENTRE
NUMBER

--	--	--	--	--

CANDIDATE
NUMBER

--	--	--	--

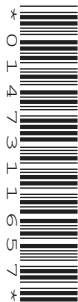

ADDITIONAL MATHEMATICS

Paper 1

0606/12

May/June 2017

2 hours

Candidates answer on the Question Paper.

Additional Materials: Electronic calculator

READ THESE INSTRUCTIONS FIRST

Write your Centre number, candidate number and name on all the work you hand in.

Write in dark blue or black pen.

You may use an HB pencil for any diagrams or graphs.

Do not use staples, paper clips, glue or correction fluid.

DO **NOT** WRITE IN ANY BARCODES.

Answer **all** the questions.

Give non-exact numerical answers correct to 3 significant figures, or 1 decimal place in the case of angles in degrees, unless a different level of accuracy is specified in the question.

The use of an electronic calculator is expected, where appropriate.

You are reminded of the need for clear presentation in your answers.

At the end of the examination, fasten all your work securely together.

The number of marks is given in brackets [] at the end of each question or part question.

The total number of marks for this paper is 80.

This document consists of **12** printed pages.

Mathematical Formulae**1. ALGEBRA***Quadratic Equation*

For the equation $ax^2 + bx + c = 0$,

$$x = \frac{-b \pm \sqrt{b^2 - 4ac}}{2a}$$

Binomial Theorem

$$(a + b)^n = a^n + \binom{n}{1} a^{n-1} b + \binom{n}{2} a^{n-2} b^2 + \dots + \binom{n}{r} a^{n-r} b^r + \dots + b^n,$$

where n is a positive integer and $\binom{n}{r} = \frac{n!}{(n-r)!r!}$

2. TRIGONOMETRY*Identities*

$$\sin^2 A + \cos^2 A = 1$$

$$\sec^2 A = 1 + \tan^2 A$$

$$\operatorname{cosec}^2 A = 1 + \cot^2 A$$

Formulae for ΔABC

$$\frac{a}{\sin A} = \frac{b}{\sin B} = \frac{c}{\sin C}$$

$$a^2 = b^2 + c^2 - 2bc \cos A$$

$$\Delta = \frac{1}{2} bc \sin A$$

- 1 On each of the Venn diagrams below, shade the region which represents the given set.

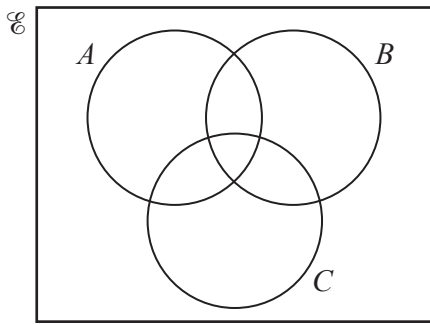

$$(A \cup B) \cap C$$

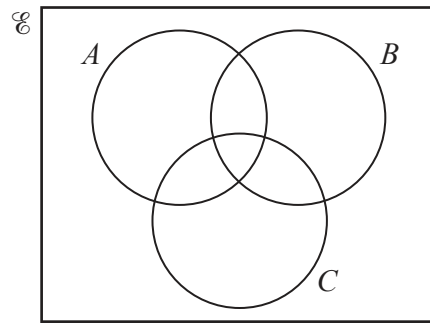

$$(A \cap B) \cup C$$

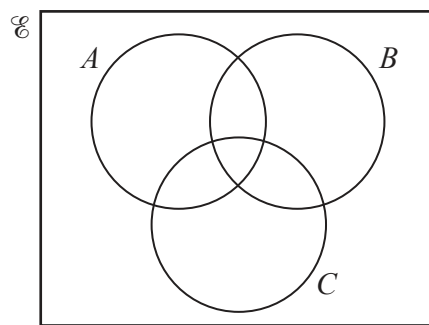

$$(A' \cap B') \cap C$$

[3]

- 2 It is given that $y = \frac{(5x^2 + 4)^{\frac{1}{2}}}{x + 1}$. Showing all your working, find the exact value of $\frac{dy}{dx}$ when $x = 3$.

[5]

- 3 Vectors \mathbf{i} and \mathbf{j} are unit vectors parallel to the x -axis and y -axis respectively.
- (a) The vector \mathbf{v} has a magnitude of $3\sqrt{5}$ units and has the same direction as $\mathbf{i} - 2\mathbf{j}$. Find \mathbf{v} giving your answer in the form $a\mathbf{i} + b\mathbf{j}$, where a and b are integers. [2]
- (b) The velocity vector \mathbf{w} makes an angle of 30° with the positive x -axis and is such that $|\mathbf{w}| = 2$. Find \mathbf{w} giving your answer in the form $\sqrt{c}\mathbf{i} + d\mathbf{j}$, where c and d are integers. [2]
- 4 The first 3 terms in the expansion of $\left(3 - \frac{x}{6}\right)^n$ are $81 + ax + bx^2$. Find the value of each of the constants n , a and b . [5]

5 A particle P moves in a straight line, such that its displacement, x m, from a fixed point O , t s after passing O , is given by $x = 4 \cos(3t) - 4$.

(i) Find the velocity of P at time t . [1]

(ii) Hence write down the maximum speed of P . [1]

(iii) Find the smallest value of t for which the acceleration of P is zero. [3]

(iv) For the value of t found in part (iii), find the distance of P from O . [1]

6 (i) Show that $\frac{\operatorname{cosec} \theta}{\cot \theta + \tan \theta} = \cos \theta$. [4]

It is given that $\int_0^a \frac{\operatorname{cosec} 2\theta}{\cot 2\theta + \tan 2\theta} d\theta = \frac{\sqrt{3}}{4}$, where $0 < a < \frac{\pi}{4}$.

(ii) Using your answer to part (i) find the value of a , giving your answer in terms of π . [4]

7 It is given that $y = A(10^{bx})$, where A and b are constants. The straight line graph obtained when $\lg y$ is plotted against x passes through the points $(0.5, 2.2)$ and $(1.0, 3.7)$.

(i) Find the value of A and of b . [5]

Using your values of A and b , find

(ii) the value of y when $x = 0.6$, [2]

(iii) the value of x when $y = 600$. [2]

- 8 (a)** A 5-digit number is to be formed from the seven digits 1, 2, 3, 5, 6, 8 and 9. Each digit can only be used once in any 5-digit number. Find the number of different 5-digit numbers that can be formed if
- (i)** there are no restrictions, [1]

 - (ii)** the number is divisible by 5, [1]

 - (iii)** the number is greater than 60 000, [1]

 - (iv)** the number is greater than 60 000 and even. [3]
- (b)** Ranjit has 25 friends of whom 15 are boys and 10 are girls. Ranjit wishes to hold a birthday party but can only invite 7 friends. Find the number of different ways these 7 friends can be selected if
- (i)** there are no restrictions, [1]

 - (ii)** only 2 of the 7 friends are boys, [1]

 - (iii)** the 25 friends include a boy and his sister who cannot be separated. [3]

9 (a) Given that $\mathbf{A} = \begin{pmatrix} 3 & 1 \\ -1 & 2 \\ 4 & 5 \end{pmatrix}$, $\mathbf{B} = \begin{pmatrix} 1 & -2 \\ 3 & 0 \end{pmatrix}$ and $\mathbf{C} = \mathbf{AB}$,

(i) state the order of \mathbf{A} , [1]

(ii) find \mathbf{C} . [3]

(b) The matrix $\mathbf{X} = \begin{pmatrix} 5 & -12 \\ 4 & -7 \end{pmatrix}$.

(i) Find \mathbf{X}^{-1} . [2]

(ii) Using \mathbf{X}^{-1} , find the coordinates of the point of intersection of the lines

$$12y = 5x - 26,$$

$$7y = 4x - 52.$$

[4]

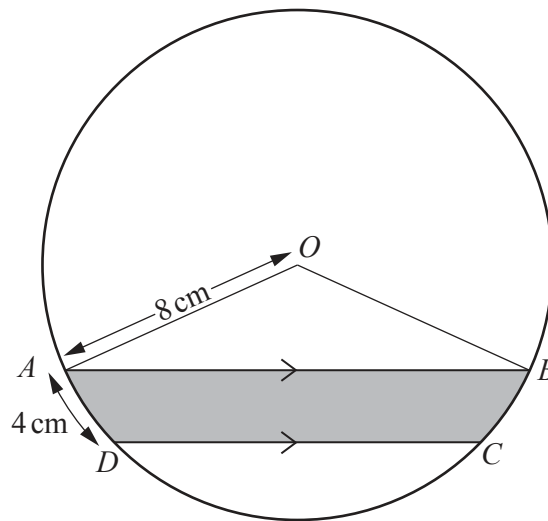

The diagram shows a circle, centre O , radius 8 cm. The points A , B , C and D lie on the circumference of the circle such that AB is parallel to DC . The length of the arc AD is 4 cm and the length of the chord AB is 15 cm.

(i) Find, in radians, angle AOD . [1]

(ii) Hence show that angle $DOC = 1.43$ radians, correct to 2 decimal places. [3]

(iii) Find the perimeter of the shaded region.

[3]

(iv) Find the area of the shaded region.

[4]

Question 11 is printed on the next page.

11 The curve $y = f(x)$ passes through the point $\left(\frac{1}{2}, \frac{7}{2}\right)$ and is such that $f'(x) = e^{2x-1}$.

(i) Find the equation of the curve.

[4]

(ii) Find the value of x for which $f''(x) = 4$, giving your answer in the form $a + b \ln \sqrt{2}$, where a and b are constants.

[4]

Permission to reproduce items where third-party owned material protected by copyright is included has been sought and cleared where possible. Every reasonable effort has been made by the publisher (UCLES) to trace copyright holders, but if any items requiring clearance have unwittingly been included, the publisher will be pleased to make amends at the earliest possible opportunity.

To avoid the issue of disclosure of answer-related information to candidates, all copyright acknowledgements are reproduced online in the Cambridge International Examinations Copyright Acknowledgements Booklet. This is produced for each series of examinations and is freely available to download at www.cie.org.uk after the live examination series.

Cambridge International Examinations is part of the Cambridge Assessment Group. Cambridge Assessment is the brand name of University of Cambridge Local Examinations Syndicate (UCLES), which is itself a department of the University of Cambridge.